

ESYBOX DIVER



CONTENTS

WARNINGS.....16

RESPONSIBILITY.....17

1 GENERAL.....18

 1.1 Applications.....18

 1.2 Pumpable Liquids.....18

 1.3 Technical Data.....18

2 INSTALLATION.....19

 2.1 Mechanical Installation.....19

 2.2 Electrical Installation.....20

3 ACCESSORIES.....21

4 FIRST INSTALLATION.....21

5 DESCRIPTION OF DCONNECT BOX 2.....22

 5.1 DCONNECT BOX 2 – ESYBOX DIVER connection.....22

 5.2 DCONNECT BOX 2 – ESYBOX DIVER association.....22

6 OPERATION.....24

7 READING AND SETTING PARAMETERS.....24

8 PROTECTION SYSTEMS.....27

 8.1 Description of blockages.....27

 8.2 Manual reset of error conditions.....28

 8.3 Self-reset of error conditions.....28

9 FACTORY SETTINGS.....28

 9.1 Restoring the factory settings.....28

10 TROUBLESHOOTING.....29

11 FIRMWARE UPDATE.....30

12 CLEANING STORAGE MAINTENANCE.....30

KEY

The following symbols have been used in the discussion:



SITUATION OF GENERAL DANGER.

Failure to respect the following instructions may cause damage to persons and property.



SITUATION OF RISK OF ELECTRIC SHOCK.

Failure to respect the following instructions may cause a situation of serious danger for personal safety.



Notes and general information.

WARNINGS



Read this documentation carefully before installation.

Installation and operation must comply with the local safety regulations in force in the country in which the product is installed. Everything must be done in a workmanlike manner.

Failure to respect the safety regulations not only causes risk to personal safety and damage to the equipment, but invalidates every right to assistance under guarantee.

The products in question in this discussion fall within the category of professional equipment and belong to insulation class 1.



Skilled personnel

The electrical and hydraulic connections must be made by qualified personnel in possession of the technical requirements indicated by the safety regulations of the country in which the product is installed.

The term skilled personnel means persons whose training, experience and instruction, as well as their knowledge of the respective standards and requirements for accident prevention and working conditions, have been approved by the person in charge of plant safety, authorizing them to perform all the necessary activities, during which they are able to recognize and avoid all dangers (Definition for technical personnel IEC 364).

It will be the installer's responsibility to make sure that the power supply system is equipped with an efficient earthing system in accordance with current regulations.

ENGLISH

To improve immunity to the possible noise radiated towards other appliances it is recommended to use a separate electrical duct to supply the inverter.

The appliance may be used by children over 8 years old and by persons with reduced physical, sensory or mental capacities, or who lack experience or knowledge, on condition that they are under supervision or after they have received instructions concerning the safe use of the appliance and the understanding of the dangers involved. Children must not play with the appliance. Cleaning and maintenance intended to be carried out by the user must not be performed by children without supervision.



Overload protection. The pump is equipped with a thermal motor protector. If the motor overheats, the motor protector switches the pump off automatically. The cooling time is about 15-20 min. after which the pump automatically switches on again. After the motor protector has tripped, it is absolutely necessary to find the cause and eliminate it. See Troubleshooting.



The power supply cable and the float switch must never be used to carry or lift the pump. Always use the pump handle.



Use is allowed only if the electric system is in possession of safety precautions in accordance with the regulations in force in the country where the product is installed (for Italy CEI64/2).



Never pull on the cable to detach the plug from the socket.



If the power cable is damaged, it must be replaced by the manufacturer or by their authorised technical assistance service, so as to avoid any risk.

Failure to observe the warnings may create situations of risk for persons or property and will void the product guarantee.

Particular warnings



Always switch off the mains power supply before working on the electrical or mechanical part of the system. Only firmly cabled mains connections are admissible. The appliance must be earthed (IEC 536 class 1, NEC and other applicable standards).



Mains terminals and motor terminals may still have dangerous voltage when the motor is stopped.



The appliance may only be used for the functions for which it was designed.

Under certain calibration conditions, the converter can start automatically after a power failure.

RESPONSIBILITY

The Manufacturer does not vouch for correct operation of the electropumps or answer for any damage that they may cause if they have been tampered with, modified and/or run outside the recommended work range or in contrast with other indications given in this manual.

The Manufacturer declines all responsibility for possible errors in this instructions manual, if due to misprints or errors in copying. The Manufacturer reserves the right to make any modifications to the products that it may consider necessary or useful, without affecting their essential characteristics.

1 GENERAL

1.1 Applications

Multistage submerged pump with integrated electronics, ideal for use in rainwater systems and irrigation networks, for pumping water from tanks, cisterns, wells, lakes and for other domestic applications requiring high pressure.

Thanks to their compact and handy shape, they are also used for particular applications as portable pumps for emergency situations such as for drawing water from tanks or rivers, draining swimming pools and fountains. Also suitable for gardening and general hobby activity.

The inverter electronics automatically switches the pump on and off, changing the frequency (ON/OFF) according to the user's water demand to keep the set pressure constant (see chapter 7.15 "SP: setting the set point pressure").

The ideal working situation is with the pump completely submerged; however, the motor cooling system allows its use up to the minimum suction height (110 mm).



These pumps cannot be used in swimming pools, ponds or basins where people are present, or for pumping hydrocarbons (petrol, diesel fuel, combustible oils, solvents, etc.) in accordance with the accident-prevention regulations in force. They should be cleaned before putting them away (See chapter "Maintenance and Cleaning").

1.2 Pumpable Liquids



Only use the pump in clean water.

The pump must not be used to pump salt water, sewage, inflammable, corrosive or explosive liquids (e.g. petroleum, petrol, thinners), greases, oils.



The temperature of the liquid to be pumped must not exceed 50°C (122°F).



If the pump is used for the domestic water supply, respect the local regulations of the authorities responsible for the management of water resources.



Maximum size of solid particles dispersed in the liquid: Diameter 1 mm (0.04 in)

1.3 Technical Data

ESYBOX DIVER pumps are equipped with a filter, which can be opened (see figure 1, A) or closed (called X) (see figure 1, B), depending on the application.

The open filter prevents the passage of suspended particles with a diameter greater than 2.5 mm.

Inside there is a splitter that prevents suction from the bottom, up to a level of 80mm. It is possible to cut or remove it to be able to suck water up to a minimum of 35mm from the bottom. (see figure 2).

Products with filter X are characterized by the X next to the pump name.

The filter X is characterized by a base, which is not watertight, with a 1" female connection. The filter X is designed to be used with the KIT X : suction kit with float (see figure 3).

Pump models are identified as below (Table 1):

	P1 [W]	Q MAX [l/min – m3/h – gpm]	H MAX [m – psi]
55/120	1250	120 – 7.2 – 31.7	55 – 78

Table 1

All technical data are marked on the technical label on the pump.
The various items are explained below:

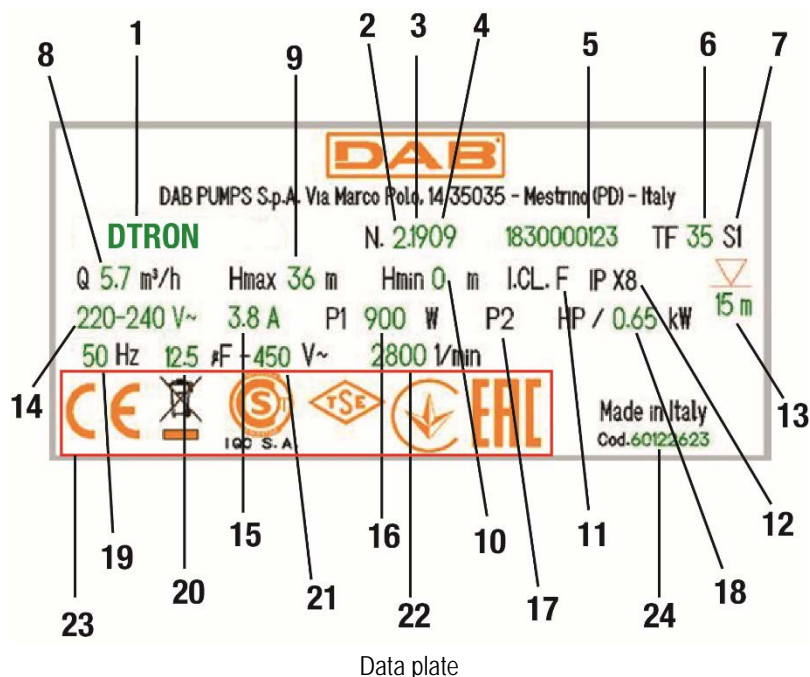

Pos.	Description
1	Description
2	Revision
3	Year
4	Week
5	Serial number
6	Maximum liquid temperature
7	Use
8	Flow rate
9	Maximum head
10	Minimum head
11	Insulation class
12	Degree of protection
13	Submersibility
14	Rated voltage
15	Ampere
16	P1
17	P2 HP
18	P2 kW
19	Frequency
20	Condenser capacity
21	Voltage
22	Rated number of revolutions
23	Logos
24	Pump code

2 INSTALLATION

Before starting up the pump, check that:



- The voltage and frequency on the pump's technical data plate correspond to the values of the power supply system.
- The pump's power cable or the pump is not damaged.
- The electrical connection must be made in a dry place, far from any possible flooding.
- The earth system must comply with the regulations.

2.1 Mechanical Installation



- Install the pump in a location that is not exposed to freezing.
- When the pump remains inactive at a temperature lower than 0°C, it is necessary to ensure that there is no water residue which could freeze and damage it.



- Hang the pump by passing the rope through the hole provided (see figure 5). Do not hang the pump by the handle.



- Do not install check valves near the pump delivery (distance less than 1 metre (3.28ft)). The pump already has a built-in check valve on delivery.

The ESYBOX DIVER pumps already contain a small expansion tank, calibrated for water hammer and small leaks. In order to reduce the number of pump starts, an auxiliary tank (Figure 6, A) with a capacity of 2 litres can be installed. If you want to install an additional non return valve (Figure 6, B), it is recommended to position it downstream from the auxiliary tank.

Do not subject the motor to excessive starts per hour. It is strictly recommended not to exceed 60 starts per hour.

It is advisable to use pipes having a minimum diameter of 1", to avoid the decrease of pump performance.

The pump is suitable for vertical or horizontal installations.

Connect a rigid or flexible pipe to the 1¼" delivery of the pump.

The maximum submersibility of the pump depends on the length of the power cable: 12m (39.4 ft) in the case of a cable 15m (49.2 ft) long; 7m (23 ft) in the case of a cable 10m (32.8 ft) long. Check the details on the technical data plate, as shown in figure 4.

In order to always guarantee a good water flow, it is advisable to enter a Setpoint pressure value to compensate for the difference in height between the service taps and the pump (see figure 7).



To facilitate installation in the tank, it is possible to remove the power cable and/or pass it through another passage hole. To remove it, follow the instructions on the product's quick guide. The electrical cable has a quick connection. Have this operation carried out by qualified personnel. Check the earth connection before commissioning the product.

The pump has:

- An air vent valve (see figure 8). This valve allows the pump to prime in a very short time. If the water level is lower than the valve level, some water may escape from the vent valve.
- A small spring and diaphragm expansion tank. This limits the number of pump restarts and compensates for small system losses. The tank protects the pump in case of water hammer. The tank does not require any refilling or maintenance.
- An overpressure valve, which prevents water hammer. In case of ice in the delivery pipe with a submerged pump, this valve protects the pump from breakage.

Installation in a well.

Install the pump so that the pump suction is at least 1 m (3.28ft) above the bottom of the well to prevent the intake of sand and impurities. Use rigid metal pipes to hang the pump and secure the pipes with brackets at the top of the well.

Installation in a tank

The minimum dimensions for the pump passage in the collecting tank are 180x185 mm (7.09x7.28 in).

Hold the pump slightly up from the bottom so as to avoid possible noises/vibrations transmitted to the tank.

The pump will make noise if it is placed on the bottom of the tank.



To avoid obstruction of the suction passages, it is recommended to check periodically that no dirt has accumulated in the collection trap (leaves, sand, etc.).

2.2 Electrical Installation

It is recommended to carry out installation as indicated in the manual, in compliance with the laws, directives and standards in force in the place of use and depending on the application.

Leakage current to earth < 5mA.



Do not remove the label on the power cable of the ESYBOX DIVER because it will be useful in case of future changes and configurations of the system.

The ESYBOX DIVER pump contains an inverter inside which there are continuous voltages and currents with high-frequency components.

For this type of equipment the possible fault currents to earth can be:

- alternating current
- unipolar pulsed current
- currents with high-frequency components

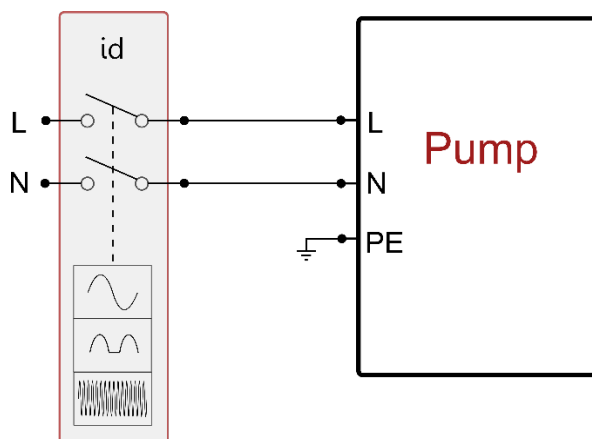

Installation example

3 **ACCESSORIES**

Accessories available	
Accessory	Description
KIT X*	Raised suction
NFC FLOATER*	Level float for stopping the pump
NFC WATER LEVEL MEASUREMENT	Measurement of the water left in the tank with level float function
SACRIFICIAL ANODE	Protection against galvanic corrosion
DOC68	Surface pump conversion kit

* The minimum overall dimensions of the pump with float inside a well or tank are as follows:
 The minimum distance between the end of the pump float and the wall is 3cm (1.18 in) (see figure 10).
 The minimum distance between the float of the suction pipe and the wall (in the case of version X) is 10cm (3.94 in) (see figure 10).

Table 2

The accessories NFC FLOATER and NFC WATER LEVEL MEASUREMENT are installed by inserting them in a special seat without requiring any electrical connection.

4 **FIRST INSTALLATION**



The pump and the DCONNECT BOX 2, if present, must be connected to the same power mains, avoiding their being galvanically separated, as for example due to the presence of open isolation transformers or switches, even single-phase ones. In particular condominium or industrial contexts, where single-phase users can be connected to different phases of the three-phase distribution provided by the public operator, the DCONNECT BOX 2 and the pump might not be able to communicate.

After having correctly connected the hydraulic and electrical part, it is sufficient to supply power and the system is ready to work.

The pump can be controlled and set through the appropriate app, installed on a smartphone or tablet.

The app can be downloaded from <https://internetofpumps.com/> or from the major stores.

To enable the app to interact with the pump, the DCONNECT BOX 2 must be correctly installed and powered. The LEDs on the DCONNECT BOX 2 monitor the connection status with the pump and the app.

5 DESCRIPTION OF DCONNECT BOX 2

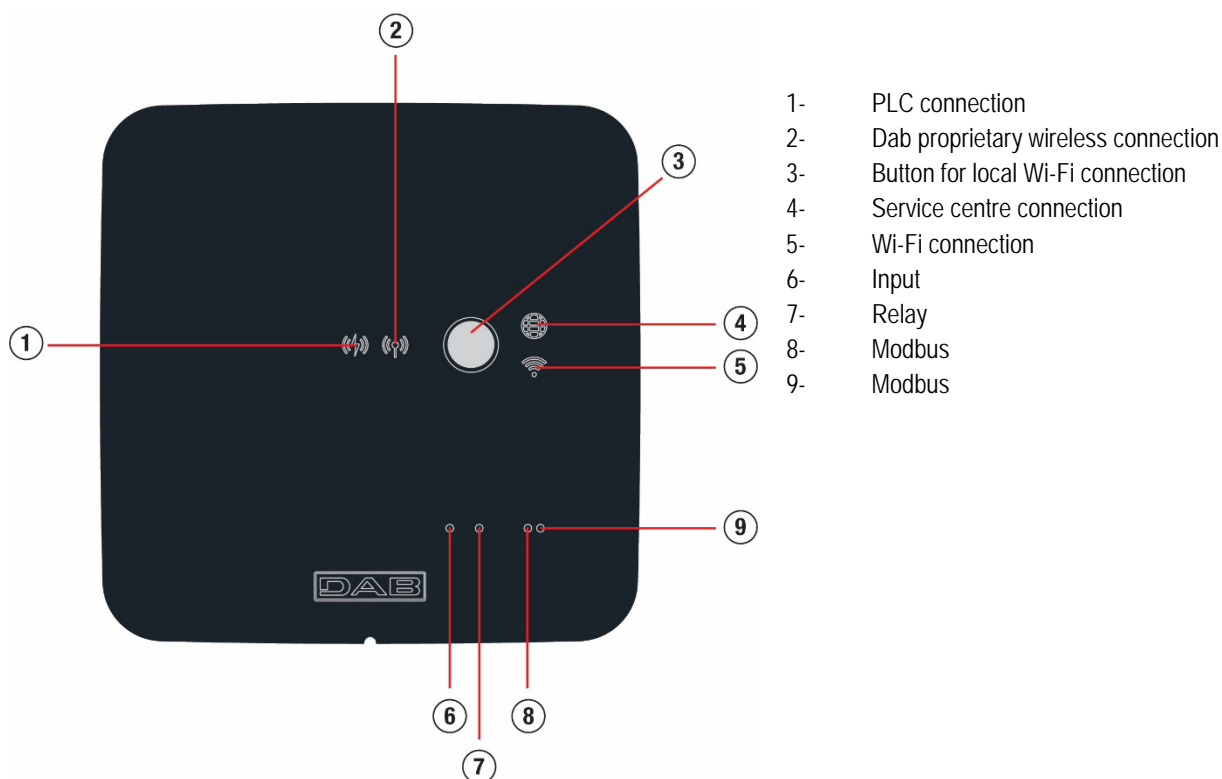

Meaning of indicators				
Indicator status	PLC (1)	Propriet. wireless (2)	Service centre (4)	Wi Fi (5)
Off	No connection	No connection	No connection	No connection
Blinking	Waiting to establish a connection	Waiting to establish a connection	-	Waiting to establish a connection
On	Connected	Connected	Connected	Connected

Table 3

Wi-Fi connection button

Used to create a direct connection between DCONNECT BOX 2 and a smartphone or tablet. Holding the button down for 5 seconds, the LEDs (1) and (4) start blinking and the DCONNECT BOX 2 goes into access point mode. When the device is in this status, it exhibits its own Wi-Fi network called DCONNECTBOX2-XXXXX to which you can connect directly through a smartphone or tablet.

5.1 DCONNECT BOX 2 – ESYBOX DIVER connection

The pump connects to the DCONNECT BOX 2 via the Power Line Communication protocol, referred to as PLC. Thanks to this communication channel, the user can monitor the pump status and actively interact through the app. In order to communicate, ESYBOX DIVER and DCONNECT BOX 2 must be associated with each other and this operation is already done in the factory. Once powered, the two units connect in a few minutes. During the device search phase, the PLC led (1) will blink regularly and once correctly connected the led will remain on with a steady light.

-  The quality of the PLC connection can be influenced by many factors:
- Power mains topology
 - Reactive loads present on the line
 - Connection length
 - Cable cross section

If there are communication problems, reduce the distance (and therefore the length of the electrical connection) between the two devices. The two devices must be connected to the same single-phase power supply and must have a common phase and neutral.

5.2 DCONNECT BOX 2 – ESYBOX DIVER association

As already described, the two units in the same package are already associated in the factory, so this procedure should be used only in case of replacement of one of the 2 units.

- 1) Disconnect ESYBOX DIVER from the mains and wait 1 min
- 2) Access DCONNECT BOX2 via Dconnect APP



- a. Access Dconnect APP via smartphone press direct Connection and select the product "Dconnect Box2".



- b. Press the Dconnect BOX2 key for 5s, until the wifi led blinks.
- c. Follow the instructions on the APP, until the wifi led stays on with a steady light and the APP shows the screen of the DCONNECT BOX2

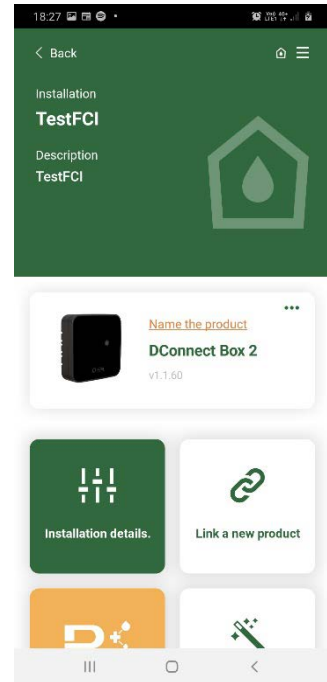
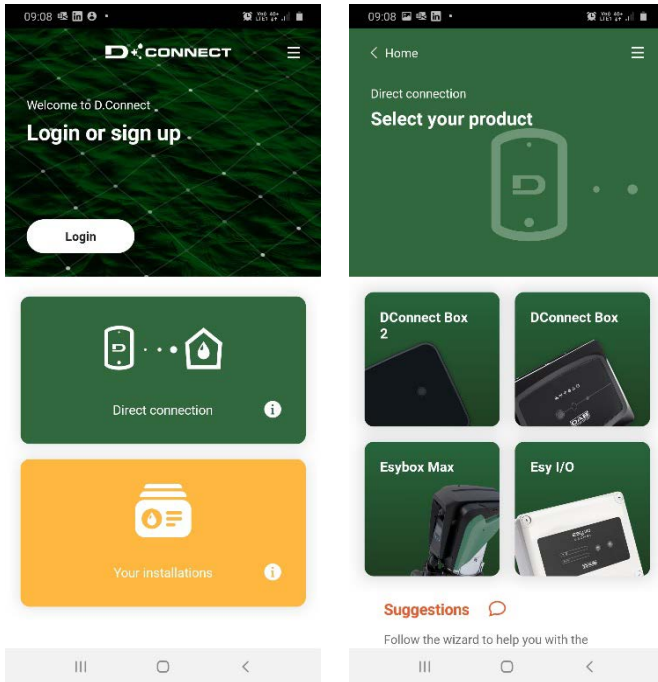

- 3) Only if Dconnect BOX2 has a previous association, delete any previous association on DCONNECT BOX 2 (Advanced Menu > Remove PLC association)

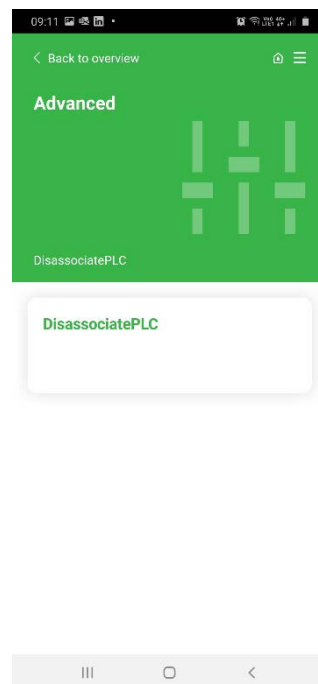

- 4) Put DCONNECT BOX 2 in the association phase
- Press "Connect a new product"
 - Select Esybox Diver

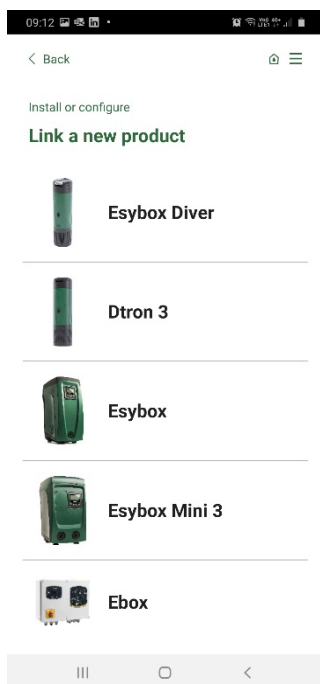

- 5) Within 20 sec connect ESYBOX DIVER to the mains and follow the procedure required in the APP.

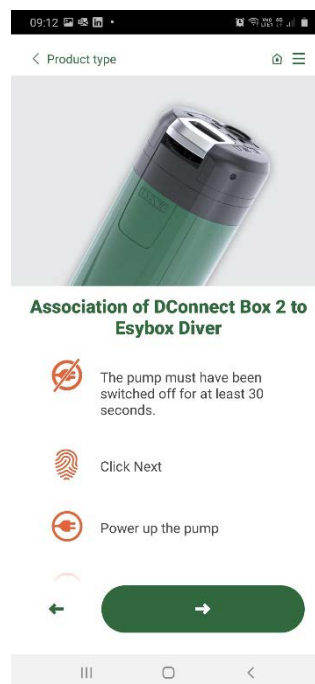

- 6) Check the PLC led status on DCONNECT BOX 2. When it remains on with a steady light, the association has been successful. At this point, your ESYBOX DIVER will also be present in the installation menu, and you can access the current status and configurations.

NOTE 1: The DConnect Cloud remote control service requires registration with the portal and, after a trial period, it requires a subscription. All information is available on the site: www.internetofpumps.com

NOTE 2: This manual refers to DConnect APP menus, colours or descriptions may change.

To get the best out of the product and its interaction with the APP and the DConnect Cloud service, consult also the online documentation and watch the demonstration videos. All the necessary information is available on the site: www.internetofpumps.com or www.dabpumps.com

6 OPERATION

Once the electropump is primed, the system starts regular operation according to the configured parameters: it starts automatically when the tap is turned on, supplies water at the set pressure (SP), and keeps the pressure constant even when other taps are turned on. When the water consumption ends, the pump stops automatically after the time T2 has elapsed.

7 READING AND SETTING PARAMETERS

Using the app you can check the operating status of the pump and change the settings. Below is the list of parameters.

- Status**
Displays the pump status.
- VP: Pressure display**
Pressure measured on the system.
- VF: Flow display**
Displays the instantaneous flow.
- RS: Rotation speed display**
Motor rotation speed in rpm.
- PO: absorbed power**
Power absorbed by the power supply line.

7.6 C1: Current display
Motor phase current in [A].

7.7 SV: Supply voltage

7.8 TE: Dissipator temperature display

7.9 Number of starts

7.10 Saving
Saving achieved compared to using an ON/OFF type pump

7.11 Energy consumption current month

7.12 Energy consumption previous month

7.13 Flow delivered in current month

7.14 Flow delivered in previous month

7.15 SP: Setting the setpoint pressure

The pump restarting pressure is linked not only to the set pressure SP but also to RP. RP expresses the decrease in pressure, with respect to "SP" caused by the pump starting

Setting too low a pressure (SP), which does not allow the water to overcome the difference in height between the pump and the point of use, can cause false dry running errors (BL). In these cases increase the SP pressure.

7.16 RP: Setting the pressure fall to restart

Expresses the fall in pressure with respect to the SP value which causes restarting of the pump. For example if the setpoint pressure is 3.0 [bar] and RP è 0.5 [bar] the pump will restart at 2.5 [bar]. RP can be set from a minimum of 0,3 a maximum of 1 [bar]. In particular conditions (for example in the case of a setpoint lower than the RP) it may be limited automatically.

7.17 OD: Type of plant

Possible values of rigidity and elasticity. The device leaves the factory with a rigid setting suitable for most systems. In the presence of swings in pressure that cannot be stabilised by adjusting the parameters GI and GP, change to the elastic mode.

7.18 GP: Proportional gain

Generally the proportional term must be increased for systems characterized by elasticity (for example with PVC pipes) and lowered in rigid systems (for example with iron pipes). To keep the pressure in the system constant, the inverter performs a type PI control on the measured pressure error. Depending on this error the inverter calculates the power to be supplied to the motor. The behaviour of this control depends on the set GP and GI parameters. To cope with the different behaviour of the various types of hydraulic plants where the system can work, the inverter allows the selection of parameters different from those set by the factory. For nearly all plants the factory-set GP and GI parameters are optimal. However, should any problems occur in adjustment, these settings may be varied.

7.19 GI: Integral gain

In the presence of large pressure drops with sudden increase in flow or slow system response, increase the GI value. On the other hand, when pressure oscillations occur around the setpoint value, decrease the GI value.

IMPORTANT: In general, both GP and GI must be adjusted to obtain satisfactory pressure adjustments.

7.20 TB: Blockage time due to dry operation

Latency time in seconds between detection of water shortage conditions and occurrence of the error.

7.21 T2: Delay in switching off

Latency time in seconds between detection of the shutdown conditions and the actual shutdown of the pump.

7.22 RM: Maximum speed

Sets a maximum limit on the number of pump revolutions.

7.23 AY: Anti cycling

The anticycling function avoids frequent switching on and off in the case of leaks in the system. The function can be enabled in 2 different modes, normal and smart. In normal mode the electronic control blocks the motor after N identical start/stop cycles. In smart mode it acts on the parameter RP to reduce the negative effects due to leaks. If set on "Disable", the function does not intervene.

7.24 AE: Enabling the anti-block function

The anti-blocking function avoids mechanical blocks in the case of long inactivity; it acts by periodically rotating the pump. When the function is enabled, every 23 hours the pump performs an unblocking cycle lasting 1 min.

7.25 AF: Enabling the anti-freeze function

If the antifreeze function is enabled the pump is automatically rotated when the temperature reaches values close to freezing point, in order to avoid breakages of the pump.

7.26 Manual disabling of the pump

Forcibly prevents the pump from starting.

7.27 Enabling float function

Enables or disables the float stop function.

7.28 Enabling stop with level sensor

Enables or disables the pump stop function according to the minimum tank level set.

7.29 Minimum tank level

Sets the tank level below which the pump stops. For the setting to take effect, the stop function with level sensor must be enabled.

7.30 Tank filling level

Value % which expresses the amount of water available in the tank in relation to the maximum level detected during the pump history. To reset the maximum tank level detected in the pump history, simply remove the level sensor from its seat and power the pump for at least 5 sec.

7.31 Setting Tank Side 1

Sets side 1 of the tank base size or the diameter of a circular tank (the interpretation changes depending on the value assigned to Side 2). If Side 1 is set to 0, all functions related to the tank level are disabled.

7.32 Setting Tank Side 2

Sets side 2 of the tank base size. By setting SIDE 2 = 0, the tank is assumed to be circular in shape with a diameter equal to SIDE 1.

7.33 Power Shower

Allows the delivery pressure to be increased for a limited time. It is used to allow the user to benefit easily from a pressure boost of the system without having to change the SP parameters and then restore them to the old values. It is activated when needed by the user. It deactivates automatically after the set time has elapsed. If during the time that the function is active, a new Start is sent or the duration time is changed, the timer is reset and the time count restarts from the beginning.

7.33.1 Power Shower Command

Comando di Start/Stop della funzionalità Power Shower.

7.33.2 Power Shower Duration

Sets the duration of the function (min 5'; max 120').

7.33.3 Power Shower remaining time

Countdown of Power Shower operating time. When it reaches 0 the function is no longer active and the pump returns to pressurise the system at setpoint pressure.

7.34 Sleep mode

Allows the delivery pressure to be reduced for a period of time. It is used to reduce possible restarts, have a better acoustic comfort and decrease consumption during the night. Once set, it is automatically activated and deactivated every day at the desired time band.

7.34.1 Sleep Mode Enabling

Command for enabling Sleep Mode function.

7.34.2 Sleep Mode start time

Sets the time of day at which Sleep Mode will be activated.

7.34.3 Sleep Mode Duration

Sets the duration of the function (min 5'; max 24h).

7.34.4 Sleep Mode remaining time

Countdown of Sleep Mode operating time. When it reaches 0 the function is no longer active and the pump returns to pressurise the system at setpoint pressure.

7.35 RF: Resetting errors
Deletes Fault and Warning history.

7.36 Error Display
Display of the errors that have occurred during system operation.

7.37 Manual reset of error conditions
Forces the deletion of the present error.

7.38 Firmware release

7.39 Firmware update

7.40 Factory settings
Restores the factory settings of the parameters.

8 PROTECTION SYSTEMS

The device is equipped with protection systems to preserve the pump, the motor, the supply line and the inverter. If one or more protections trip, the one with the highest priority is immediately notified on the display. Depending on the type of error the motor may stop, but when normal conditions are restored the error status may be cancelled immediately or only after a certain time, following an automatic reset.

In the event of a blockage due to an error, you can attempt to exit the error conditions manually by sending the appropriate command. If the error condition remains, you must take steps to eliminate the cause of the fault.

In the event of blocking due to one of the internal errors E18, E19, E20, E21 it is necessary to wait 15 minutes with the machine powered until the blocked status is automatically reset.

Blockage conditions	
Indication	Description
PH	Cutout due to pump overheating
BL	Blockage due to dry operation
BP1	Blockage due to reading error on the delivery pressure sensor
PB	Blockage due to supply voltage outside specifications
OT	Blockage due to overheating of the power stages
OC	Blockage due to motor overload
NC	Blockage due to motor disconnected
Ei	Blockage due to i-th internal error
Vi	Blockage due to i-th internal voltage out of tolerance
EY	Block for cyclicity abnormal detected on the system

Table 4 Indication of blockages

8.1 Description of blockages

8.1.1 "BL" Anti Dry-Run (Protection against dry running)

In the case of dry running the pump is stopped automatically after the time TB.

After having restored the correct flow of water you can try to leave the protective block manually by sending the Error Reset command. If the alarm status remains, or if the user does not intervene by restoring the flow of water and resetting the pump, the automatic restart will try to restart the pump.



If the parameter SP is not correctly set, the protection against dry running may not work correctly.

8.1.2 Anti-Cycling (Protection against continuous cycles without utility request)

If there are leaks in the delivery section of the plant, the system starts and stops cyclically even if no water is intentionally being drawn: even just a slight leak (a few ml) can cause a fall in pressure which in turn starts the electropump.

The electronic control of the system is able to detect the presence of the leak, based on its recurrence. The Anti-Cycling function can be excluded or activated in Basic or Smart mode.

In Basic mode, once the condition of recurrence is detected the pump stops and remains waiting to be manually reset. This condition is communicated to the user with the "ANTICYCLING" message. After the leak has been removed, you can manually force restart by sending the Error Reset command.
 In Smart mode, once the leak condition is detected, the parameter RP is automatically increased to decrease the number of starts over time.

8.1.3 Anti-Freeze (Protection against freezing of water in the system)

The change of state of water from liquid to solid involves an increase in volume. It is therefore essential to ensure that the system does not remain full of water with temperatures close to freezing point, to avoid breakages of the system. This is the reason why it is recommended to empty any electropump that is going to remain unused during the winter. However, this system has a protection that prevents ice formation inside by activating the electropump when the temperature falls to values close to freezing point. In this way the water inside is heated and freezing prevented.



The Anti-Freeze protection works only if the system is regularly fed: with the plug disconnected or in the absence of current the protection cannot work. However, it is advised not to leave the system full during long periods of inactivity: drain the system accurately through the drainage cap and put it away in a sheltered place.

8.1.4 "PB" Blockage due to supply voltage outside specifications

This occurs when the allowed line voltage at the supply terminal assumes values outside the specifications. It is reset only automatically when the voltage at the terminal returns within the allowed values.

8.2 Manual reset of error conditions

In error status, the user can cancel the error and force a new attempt by sending the Error Reset command.

8.3 Self-reset of error conditions

For some malfunctions and blockage conditions, the system attempts automatic self-reset.

The auto self-reset procedure concerns in particular:

- "BL" Blockage due to dry operation
- "PB" Blockage due to line voltage outside specifications
- "OT" Blockage due to overheating of the power stages
- "OC" Blockage due to motor overload
- "BP" Blockage due to fault of the pressure sensor

For example, if the system is blocked due to dry running, the device automatically starts a test procedure to check whether the machine is really left definitively and permanently dry. If during the sequence of operations an attempted reset is successful (for example, the water comes back), the procedure is interrupted and normal operation is resumed. Table shows the sequences of the operations performed by the device for the different types of blockage.

Automatic resets of error conditions		
Indication	Description	Automatic reset sequence
BL	Blockage due to dry operation	- One attempt every 10 minutes for a total of 6 attempts. - One attempt every hour for a total of 24 attempts. - One attempt every 24 hours for a total of 30 attempts.
PB	Blockage due to line voltage outside specifications	- It is reset when it returns to a specific voltage.
OT	Blockage due to overheating of the power stages	- It is reset when the temperature of the power stages returns within the specifications.
OC	Blockage due to motor overload	- One attempt every 10 minutes for a total of 6 attempts. - One attempt every hour for a total of 24 attempts. - One attempt every 24 hours for a total of 30 attempts.

Table 5 Self-reset of blockages

9 FACTORY SETTINGS

The device leaves the factory with a series of preset parameters which may be changed according to the user's requirements. Each change of the settings is automatically saved in the memory and, if desired, it is always possible to restore the factory conditions.

9.1 Restoring the factory settings

It restores the value of all configuration parameters to factory default values.

NOTE: Once the factory values have been restored it will be necessary to reset all the parameters that characterise the system (gains, setpoint pressure, etc.) as at the first installation.

Factory settings			
Identifying code	Description	Value	Installation Memo
SP	Setpoint pressure [bar]	3.0	
RP	Pressure decrease to restart [bar]	0.5	
OD	Type of plant	Rigid	
TB	Blockage time due to dry operation [s]	15	
T2	Delay in switching off [s]	10	
GP	Proportional gain coefficient	0.5	
GI	Integral gain coefficient	1.2	
RM	Maximum speed [rpm]	5000	
AE	Anti-blocking function	Enabled	
AF	Antifreeze	Enabled	
AY	Anticycling Function AY	Disabled	
Power Shower Duration	Power Shower function duration [hh:mm]	30'	
Sleep Mode Enabling	Sleep Mode function enabling	Disabled	
Sleep Mode start time	Sleep Mode function start time	23:00	
Sleep Mode Duration	Sleep Mode function duration [hh:mm]	7 h	
Float function	Enabling float	Enabled	
Pump stop based on level	Enabling pump stop based on minimum tank level	Disabled	
Minimum level for pump stop	Level below which the pump stops [cm].	0	
L1 tank	Setting tank side 1 or diameter [cm]	0	
L2 tank	Setting tank side 2 [cm]	0	

Table 6 Factory settings

10 **TROUBLESHOOTING**



Before starting to look for faults it is necessary to disconnect the power supply to the pump (take the plug out of the socket). If the power cable or any electrical part of the pump is damaged, the repair or replacement must be carried out by the manufacturer or by their technical assistance service, or by a person with equivalent qualifications, so as to prevent any risk.

FAULTS	PROBABLE CAUSES	REMEDIES
The pump does not turn on or does not stay on.	Pump is not powered.	Check power supply.
	No water.	Restore the water level.
	Utility at a level higher than the system restarting pressure level.	Increase the system restarting pressure level by increasing SP or decreasing RP.
La pompa non si arresta.	Leak in the system.	Check the system, find and eliminate the leak.
	Impeller or hydraulic part clogged.	Dismantle the system and remove the obstructions (assistance service).
	Air getting into the suction pipe.	Check the suction pipe, find and eliminate the cause of air getting in.
The flow rate is insufficient.	Suction clogged.	Remove the obstructions
	Suction pipe diameter insufficient.	Use a pipe with diameter at least 1"
The pump does not deliver water.	The suction grid or the pipes are blocked.	Remove the obstructions.
	The impeller is worn or blocked.	If worn, replace the impeller, if blocked, remove the blockage: remove the impeller inspection cap and turn the impeller to unlock it.
	The head required is higher than the pump's characteristics.	
The pump starts without utility request	Leak in the system.	Check the system, find and eliminate the leak.
The pump does not start and the status signal is BL	Lack of water or pump not primed	Prime the pump and check whether there is air in the pipe.
	Obstruction in suction	Check whether the suction or any filters are blocked.
	Setpoint not reachable with the set RM value	Set a RM value that allows the setpoint to be reached.
	The non-return valve is blocked	Remove obstruction on the non-return valve

ENGLISH

The pump does not start and the status signal is PB	Low supply voltage	Check the presence of the correct supply voltage.
	Excessive voltage drop on the line	Check the section of the power supply cables.
The Pump and DConnect Box 2 do not connect to each other (PLC DCONNECT BOX2 led steady red) (paragraph 10)	They are galvanically separated.	Check that the two units are on the same power supply and in the same phase.
	They are too far apart.	Connect the two units at a shorter distance.
	The two units are not associated (only in case of replacement of a unit)	Perform the association procedure
The pump does not start and the status signals error E17	Blocked rotor	<ul style="list-style-type: none"> • Update Fw version to the latest available • Wait 25 minutes with the machine powered
		<ul style="list-style-type: none"> • for the automatic restoration of the blocked status • Check that the shaft turns freely
The pump does not start, the status indicates one of the following errors: E19, E20, E21, E22, E23, E24	SW safety error	It is necessary to wait 25 minutes with the machine powered for the automatic restoration of the locked status.

Table 7 Troubleshooting

11 FIRMWARE UPDATE

The ESYBOX DIVER firmware can be updated via cloud or app using DConnect Box 2.

When a new firmware is available, the interface sends a notification and gives the user the opportunity to start the update..

12 CLEANING STORAGE MAINTENANCE

The pump does not require any maintenance. Frost can damage the pump. In very cold temperatures, remove the pump from the liquid, empty it and store it away from frost. Before any cleaning work is carried out, the pump must be disconnected from the power mains.

Once the pump has been removed from the liquid, it is advisable to clean the following parts with a simple jet of water:

- Filter (open, see figure 1A)
- Suction filter with float, in case of version X (see figure 3)
- Non-return valve. In this case, remove the part concerned as shown in figure 11.

Be sure to reassemble all parts correctly.



www.whiteint.com.au

www.whiteint.co.nz

Please always refer to our website for further technical information & new product innovations

Disclaimer: Every effort has been made to publish the correct information in this manual.
No responsibility will be taken for errors, omissions or changes in product specifications.

© 2020 Copyright White International Pty Ltd

TM ® - WARNING: Please be aware that various brands & products depicted within this document are subject to trademark, patent or design registrations. Infringement of any intellectual property contained within this document without express written authority by the appropriate intellectual property holder may result in further legal action to be taken. For any queries regarding use of the contained information please feel free to contact White International Pty Ltd.